

Folding Cockpit Table

By Eric Palmer, Shrimper 252 (Jaunty), (2002)

This is a lightweight, folding table which is quick & easy to erect and fit and not difficult to construct using readily available materials. It is held in place at the after end of the cockpit by positioning a slotted Tufnol piece on the leg frame over the safety line eyebolt fitting. The legs rest on the rim of the cockpit sump and a folding brace supports the top.

When not in use the table can be folded & stowed against the side seats at the forward end of the cockpit on clips, secured by a bungee cord. On outboard Mk 1 boats it will also fit under the cockpit sole.

Materials used should be of good quality, ideally hardwood and marine plywood, but clean softwood and exterior grade ply can be used if these are not available. Fastenings should be marine grade with brass hinges.

1. The top is made from 9mm ply, 24" (600) long x 15" (380) wide, edged with wooden 'hockey stick' moulding to provide a small lip.
2. The leg frame is made from 1 $\frac{3}{4}$ " x $\frac{3}{4}$ " (44 x 19) timber, 23" (635mm) high x 12" (300mm) wide overall. An additional timber batten 13" (330) long is attached to the underside of the table top and attached to the leg frame with two hinges.
3. The Tufnol attachment piece should be at about $\frac{3}{8}$ " (8 mm) thick x 3" x 2" (75 x 50), suitably slotted to fit the safety line eyebolt. The Tufnol is attached to a batten located across the aft side of the leg frame at the correct height to allow the slot to drop securely over the eyebolt. The leg length may have to be adjusted for a Mk 2 boat with self-draining cockpit.
4. The bracing strut is made from 1 $\frac{3}{4}$ " x $\frac{3}{4}$ " (44 x 19) timber, overall length 27 $\frac{1}{2}$ " (700 mm) approx, hinged at both ends and at mid point. A short length of 1 $\frac{3}{4}$ " x $\frac{3}{4}$ " (44 x 19) timber fitted to the underside of the top acts as the forward attachment for the strut. The strut is locked by a clip made by attaching a piece of timber or ply with a single screw or bolt to the underside of the strut so that it pivots across the centre hinge.

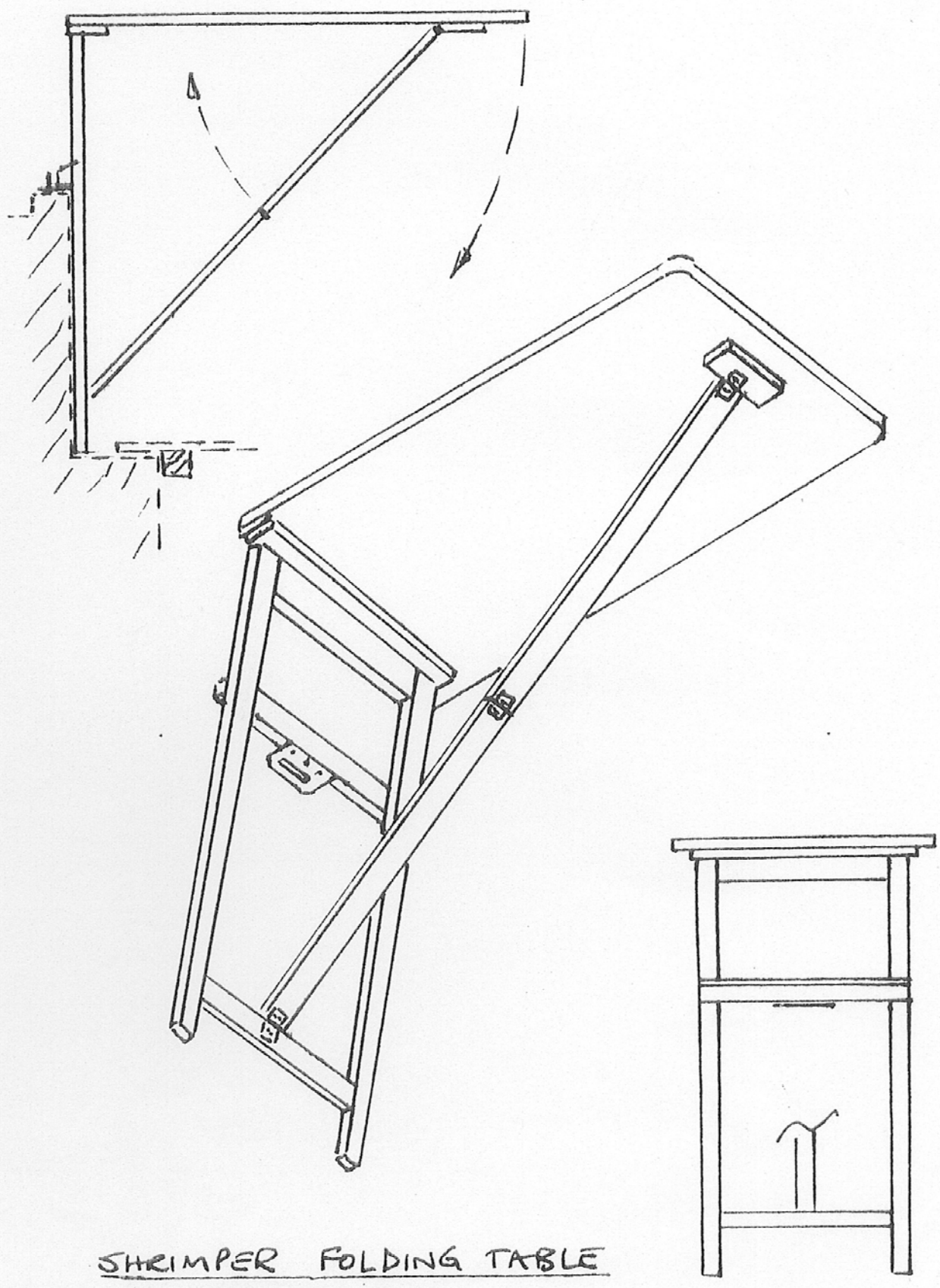

SHRIMPER FOLDING TABLE